

Ambient Intelligence Technologies for the Product Lifecycle

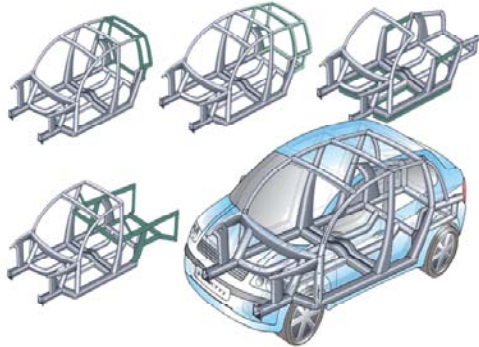

Rationale

Economic

This domain of research is of vital importance for Europe. Improving the knowledge of the product and production processes will in the longer term imply that the needed engineering knowledge is maintained, making Europe more competitive on a worldwide scale and enhancing the prospects for employment in Europe (1).

The European Council (Brussels 25/26 March 2004) report identifies de-industrialisation as a risk and looks forward to receiving substantial support from the Commission, including concrete steps aimed at the improving competitiveness of the European industry (2).

Ambient intelligence technologies offer tremendous opportunities for industrial change in the emerging global Knowledge- based Economy. These technologies contribute indeed to the modernisation of many industries from both manufacturing and service sectors, by enabling networking, mass customisation, agility, knowledge engineering, and anthropocentric process automation.

(1) Although manufacturing creates less than 30% of the European jobs directly, it indirectly creates more than 70% of the European jobs if the full product lifecycle is considered (Manufature 2003 conclusions).

(2) Presidency Conclusions – Brussels, 25/26 March 2004, comm. SN 100/04, paragraph 17.

Environmentally sustainable growth

Growth in Europe, to be sustainable, must be environmentally sound. Improvements in energy efficiency and clean technologies that fully exploit the synergies between the enterprise and the

environment are essential [Presidency conclusions].

Key Areas of Research

- Frameworks, new business- and service models
- Distributed semi-structured data management
- Smart objects identification
- Secure and trusted communication
- Wireless radio frequency based technologies
- Real time monitoring of flows
- Middleware interfacing with legacy databases
- Agent based systems
- Knowledge discovery in distributed semantic networks
- Self-configuring networks
- Community memories
- Operations research

Objective

Enabling organizations in a networked world to deliver better products in a more efficient way faster to the market.

By enhancing the product and the product lifecycle processes using ambient intelligence technologies.

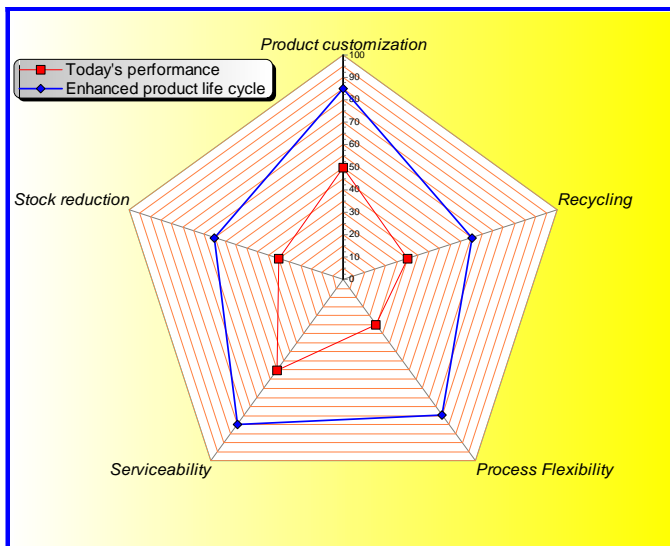

Enhancements can address customization, reduction in material waste and increased recycling, increasing process flexibility and the lifespan of a manufacturing unit, the serviceability of a product, self diagnostics, enhanced monitoring and quality, reduced stock levels in the production

and distribution processes, and much more...

Designing in value

Future products and services will be designed to offer customers more value and enable manufacturers to respond faster and in a flexible manner to the ever increasing market demands.

Today's manufacturing environment is increasingly competitive, with customers demanding ever more advanced and sophisticated products, greater choice and shorter delivery times. To satisfy this demand for differentiated and customised products, companies with different expertise must collaborate. But they need to do so in ways which ensure that the value chain remains flexible, so as to realise the full benefits of rapid product innovation and open competition.

In addition, manufacturers are looking to make their products "smarter" by designing in added-value services as part of the customer offering. This "extended product" approach combines a product with services and enhancements that improve marketability. The customer proposition may subsist more in the benefits of the value-added elements than the physical product itself. Enhancements can incorporate tangible features that make the product more intelligent, customised or user-friendly, including embedded features like maintenance. Other aspects, such as services, engineering or software, are intangible and make the offering more information or knowledge intensive.

Ambient Intelligence Technologies for the Product Life Cycle

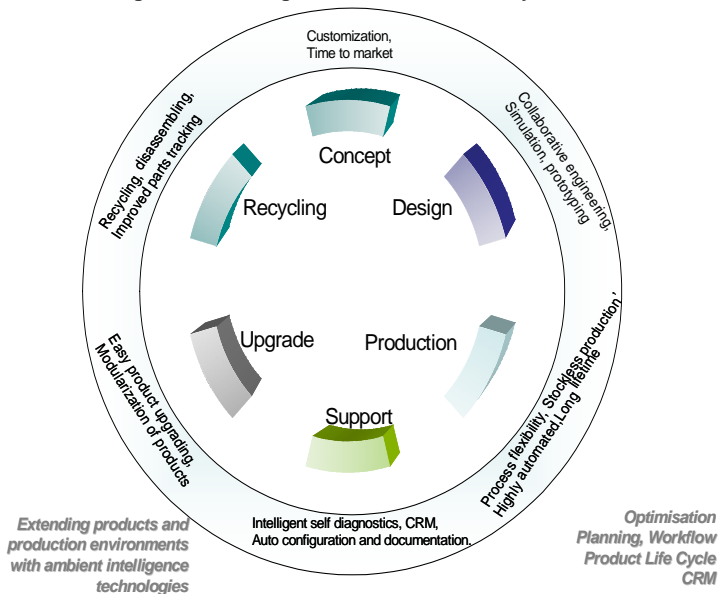

FP6 IST Projects in the Cluster

(as of September 2004)

[IP] **ILIPT**: Intelligent Logistics for Innovative Product Technologies
website : <http://www.ilipt.org>

[STREP] **SPIDER-WIN**: Supply Information Dynamic Exchange and Control by Web-based Interaction Network
website : <http://www.spider-win.de>.

[SSA] **V-CES**: The Virtual Cost Engineering Studio

[SSA] **VERITAS**: Virtual Enterprises for Integrated Industrial Solutions
website : <http://www.veritas-eu.net>

[CA] **CO-DESNET**: The European Virtual Institute on Collaborative Demand & Supply Networks